



OPUR SUPERCOMPACT

With CE certificate EN12566-3

User manual



For

OPUR SUPERCOMPACT 5 MB and 7 MB



1. Content

1. content
2. introduction
3. installation guidelines
 - Where to install
 - How to install
 - Connection diagram
 - Elektric connections
4. Application domains
5. Important safety information
6. description
7. operation
8. operating conditions
9. Alarm
10. User guide security and tuning
11. In case of an emergency
12. maintenance
13. Technical specifications
14. Overview of the influence of substances on water treatment, and alternatives
15. Available accessories
16. Garantie

2. Introduction

Boralit is proud of a rich company history and has built up a strong experience in the field of polyethylene rotational moulding for more than 35 years. It can offer a range of over 300 certified types of systems for: wastewater treatment (for household and SME purpose), diesel fuel tanks, rainwater collection tanks, grease traps, separators and pumping stations .

The material polyethylene is recyclable, corrosion free and resistant to most damaging products, and all our tanks include an additional UV stabilization to protect the PE material from UV damage.

The Boralit Opur Supercompact MB wastewater treatment plant is designed for the treatment of household waste waters, for households with 2-7 people that are not connected to the sewer system.

Our systems are certified following the European standard for waste water treatment plants (CE EN 12566-3), and will allow to meet several local standards for household effluent discharges (e.g. VLAREM II, arrêté Wallon,...).

The CE approval requires to send back to us the included document for registration of your system, properly filled out.



3. Installation guidelines

**The client acknowledges to have received a copy of this and agrees.
The installation requirements should be read FIRST BEFOR placement.**

In the event of loss by the customer of the installation requirements the customer must always ask for a new copy of the installation requirements at Boralit nv, or download them from the Boralit Web site.

3.1 INSTALLATION IN CONSOLIDATED SAND

3.1.1 WHERE TO INSTALL?

Find a place where the facility can be easily installed and where the drain of the house can be led. Check for enough fall to the drain of the infiltration-facility. Make sure there is no possible flow-back from flooding, high water, heavy rainfall. The pump(s) should be in a dry and well-ventilated place. At preference in a cellar, garage, shelter or a separate room. The standard delivered aeration pump can be installed up to 15 m from the aeration tank. In case there is a greater distance between the pump and the system, please contact us as this will require a pump with more power. It is also possible to install a special stainless steel pump housing (see B.2.5 options) near the wastewater treatment system. This way, the pump can be installed near the aeration tank and it will be protected against bad weather. What's more, the pump will be easy to reach during maintenance of the system.

3.1.2 HOW TO INSTALL?

- Dig a square pit of adequate dimensions. See to it that all ground water present in the pit, is pumped out. Once the pit is dry, it must be covered by at least 10cm of consolidated sand (150 kg/m³). Make sure the consolidated sand is level so the tank is installed perfectly level to insure proper flow through the system. A concrete cap can be placed over the tanks to prevent tank floatation from groundwater pressure.
- Install the facility in correct order (tank 1: primary-sedimentation, tank 2: aeration tank, tank 3: secondary sedimentation). The arrows show the direction in which the water will flow.
- Connect the drain pipe of the house (if necessary, install a grease-trap between drain and wastewater treatment system) with the inlet of the facility (tank1: primary sedimentation).
- Connect the outlet of the wastewater treatment system with the drain pipe that goes to discharge or dispersal area, ... Make sure there is no flow-back possible.
- Connect the tanks (only for types WZ).
- Fill up the 4 tanks with water through the first tank and let the water flow from the first tank through the other tanks until all tanks are filled with clear water. At the same time backfill the pit round the tanks with consolidated sand (150 kg/m³) up to the level of the in-and outlet.
- Pull up the ballast-blocks from the aeration tank with the provided ropes. Screw the aeration discs on the provided screw thread and lower the blocks back into the tank.
- Saw the risers to the correct height to have them at ground level.
- Make sure there is adequate ventilation of the primary sedimentation tank and on the aeration tanks. For this purpose the primary settling tank 2 has been provided with a 50 mm pipe and a muff pipe DN100 (Ø110 mm) in the riser, connected to a T of 110 mm with reduction to 50 mm. Lead the 110 mm to a well-ventilated place. Bring it to sufficient height above the ground and fix 2 curves 110 mm 90° to get a chimney-effect.
- Connect the aeration tubes and the aeration pump and electro valve. For this, use a tube of 110 mm through which the aeration tube goes from the aeration pump to the manhole of tank 3, according to the connection diagram.
- Back-fill the pit with consolidated sand (150 kg/m³) to requested level.

Remark: In case the facility gets embedded deeper in the ground than is permitted by the PE-riser, or in case one wants to make a manhole himself (e.g. brick-work) a support structure or concrete cap should be installed. This structure or cap should not rest on the tank nor on the brick-work and should divert the pressure to undisturbed ground.



3.1.3 Connection diagram

- 1: Control box
- 2: Mains voltage
- 3: Pump
- 4: Manifold air
- 5: Electro valve
- 6: Airlift
- 7: Connection alarm
- 8: Aeration disc
- 9: Tube between electro valve and airlift
- 10: Tube between connection alarm and aeration disc
- 11: Control pump
- 12: Control electro valve
- 13: Plastic tube 6 mm from the control box to connection alarm

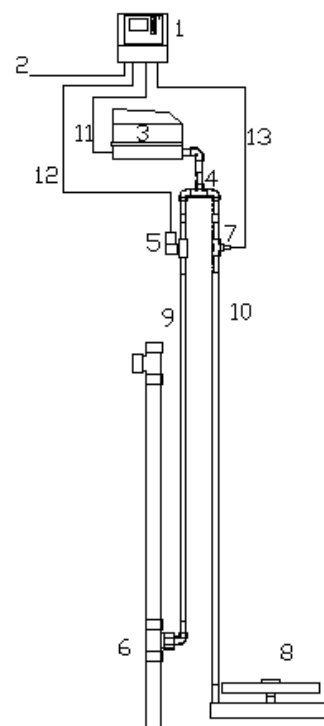

ATTENTION : In case any vehicles might drive in the immediate surroundings of the facility:

- A strong cover should be used e.g. pedestrians' 50kN, vehicles 125 kN, trucks 250 kN or heavy weight vehicles 400 kN.
- The cover should be cast in a sufficiently strong, reinforced concrete slab (=pressure plate) to avoid any immediate pressure on the tanks (ask for information at a recognized technician or desk). The slab should rest on the ground around the pit that has not been churned.
- The PE covers which come standard with the wastewater treatment system cannot carry the weight of persons/vehicles passing above the system and have no lock. That's why you should always install Boralit PE covers that are adapted to the persons/traffic passing above them and which can be locked.



3.1.4 Elektrical connections

- Connect (Branch) the control box to a grounded receptacle (230V)
- Make sure correct fuses guard the electrical circuit.

3.2 INSTALLATION IN SAND

Follow above instructions and If there is no groundwater, the consolidated sand can be replaced by regular sand. Please contact us if the tank becomes more deeply embedded in the ground than is permitted by the PE-riser.

4. Application areas

Our treatment plants are made for the treatment of all household wastewaters such as toilets, bathroom, washing machine, sinks, kitchen,...

Chemical substances, paints and medication are to evacuated separately.

Attention : also rainwaters can never enter the system since it will hinder proper functioning of the installation

The treatment system can handle most common regular soaps and hygiene products for daily use. It is recommended to use as much as possible environmental-friendly products, but it is not a must to achieve good effluent results. In case of any doubt please make sure to consult Boralit or our local distributor for further advise.

Rainwaters can be collected in a separate tank through an adapted rainwater filter, an can be re-used for the toilets, washing machines, outside water taps,Also for this application Boralit has the proper product offer available.

5. Important safety information

Mechanical

- The tanks are not suited for traffic driving over the installation.
- A strong cover should be used e.g. pedestrians' 50kN, vehicles 125 kN, trucks 250 kN or heavy weight vehicles 400 kN. The cover should be cast in a sufficiently strong, reinforced concrete slab (=pressure plate) to avoid any immediate pressure on the tanks (ask for information at a recognized technician or desk). The slab should rest on the ground around the pit that has not been churned.
- When the tank is close to a traffic area, it is best to foresee additional protection with fencing or plants. Also possible groundpressures need to be considered, and if needed please consult a specialized engineering firm.
- The PE covers that come standard with the wastewater treatment system cannot carry the weight of persons/vehicles passing above the system and have no lock. That's why you should always install Boralit PE covers or another cover type adapted to the persons/traffic passing above them and which can be locked.
- When opening the tank / system, it is recommended to protect the working area with clear markings, in order to avoid that e.g. pedestrians fall into the tanks.
- The areation disk can be removed and cleaned by simply lifting the concrete block with the foreseen ropes, to avoid the need to descend in the tank .

Electrical

- The control box is to be connected to the power grid by following and respecting the guidelines, and this by a certified installer.
- During maintenance works it is recommended to disconnect the control box from the power grid.
- All electric parts are to be protected following the local / national safety regulations of your country

Hygiene

- The effluent waters are not drinkable and cannot be used for consumption
- Always wear adapted gloves during maintenance and tuning works
- Always wash and rinse your hands after maintenance and tuning Works, and do not eat or drink while working on the installation

6. Description

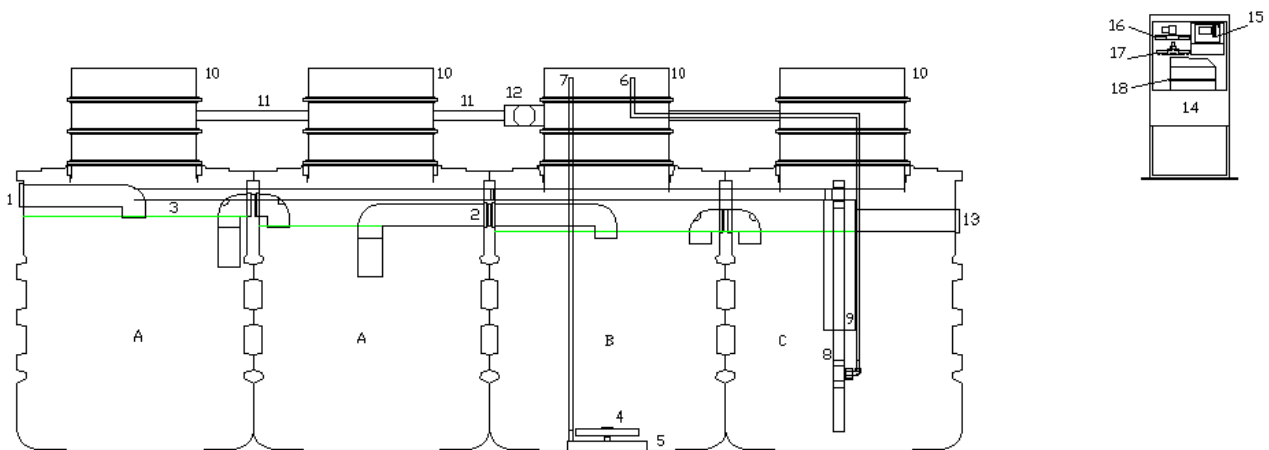

A: Primary settlement B: Bioreactor (Aeration chamber) C: Settlement

Legend:

1. ENTRY \varnothing 110
2. Exit primary settlement
3. Backflow sludge
4. Aeration disc with micro-perforations
5. Removable concrete bloc for aeration disc
6. Connection to airlift
7. Connection to aeration disc
8. Sludge return
9. Still water zone
10. Manhole with riser
11. Ventilation of primary settlement
12. Ventilation of biorotor
13. Exit \varnothing 110
14. Stainless steel box
15. Control box
16. Electro valve
17. Connection alarm
18. Pump



7. Operation

The Opur Supercompact MB wastewater treatment plant is based on the moving bed technology. Opur Supercompact is built with 4 tanks that are connected to each other as a monoblock. The system consists of 2 first settlement tanks (1 and 2), aeration tank(3) and final settlement tank (4), and has to be installed underground.

1. First settlement:
In the first settling tanks, the solid particles are stopped and gradually liquefied. Accidental dumping of small amounts of detrimental substances are partially taken care of in this tanks. The biological transformations are done anaëroob (without oxygen).
2. Aeration tank:
By means of a bubble aerator oxygen is dissolved into the liquid, which enhances growth of aerobic bacteria. These bacteria will consume the biological waste. The continuous flow of air bubbles also creates optimal mixing and consumption of the biological waste and enables treatment of waste waters entering the system.
3. Final settlement :The third tank is the second settling tank (secondary sedimentation), based on a double final settlement . Here the sludge settles down and from this tank the purified water is discharged from the still water area. There is no need to add bacterias during the start-up of the system. A sludge return system will return separated sludge to the aeration tank, and will help to bridge periods with limited or no influent (e.g. during vacation period) without negative impact on effluent results

8. operating conditions

- The system is conceived for underground installation, which also gives a protection against temperature swings
- The system, the entrance and exit piping are to be installed deeply enough, in order to protect against frost
- Electric components need to be connected, installed and protected as instructed.
- The system has to work continuously, also during periods of absence, the aeration pump needs to remain connected and operating.

9. Alarm

An alarm is included in the standard package and functions by means of differential pressure. It is to be installed between the aerator and the aeration pump.

Functioning

The box contains a pre-mounted pressure alarm. When connecting the system the buzzer alarm will not work. As soon as the pressure drops, e.g. due to a defect in the air pump, disconnected aeration disc, disconnected hose, ..., the buzzer is activated. There can be a minor time interval between the occurrence of the defect / problem and the activation of the alarm.



10. User manual for safety and malfunctioning

Following malfunctioning can occur

Problem	Possible cause	Possible remediation
Air pump does not work	No power	Check and repair power supply and /or connection
	Pump failure	Have pump checked by certified repair man. If needed replace pump
	Control box failure	Have control box checked by certified repair man. If needed replace it
Bad smells	Pump failure	See above
	Aeration disc is contaminated or clogged	Clean or replace aeration disc
	Air hose blocked	Replace or unblock hose
	Unsufficient ventilation	Check and guarantee proper ventilation
	Maintenance required	Desludge the system
No sludge return	Air hose blocked	Replace or unblock hose
	Sludge return blowked	Unblock sludge return tube
	Pump failure	See above

11. In case of an emergency

- Always disconnect the air pump from the power grid
- Take the necessary safety precautions (see 5)
- Have the problem solved
- Re-start the system (see 8)

12. Maintenance

Attention: To guarantee the proper operation and functioning of the system a regular maintenance and technical check-up is required

There is the possibility to sign a maintenance contract for annual maintenance with a Boralit Certified Maintenance Company.

In case of insufficient or unproper maintenance, one can not expect that the system will fulfill the expected technical performance nor to reach the expected effluent results.

In case of changes made to the system and/or its parts by a non-certified company, one can not expect that the system will fulfill the expected technical performance nor to reach the expected effluent results.



13. Technical Specifications

	SuperCompact 5 MB	SuperCompact 7 MB
Number of people equivalent (P.E.)	2 - 5 P.E.	5 - 7 I.E.
Content first settlement (liters)	2 x 1.100 L	2 x 1.600 L
Aeration (liters)	1.100 L	1.600 L
Final settlement (liters)	1.100 L	1.600 L
total (liters)	4.400 L	6.400 L
Weight first settlement (Kg)	2 x 60	2 x 70
Aeration (Kg)	60	70
Final settlement (Kg)	85	95
pump (Kg)	5,2	5,2
First settlement: length (mm)	1.180	1.290
width (mm)	1.180	1.290
height (mm)	1.910	2.200
Aeration : length (mm)	1.180	1.290
width (mm)	1.180	1.290
aeration (mm)	1.910	2.200
Final settlement: length (mm)	1.180	1.290
width (mm)	1.180	1.290
height (mm)	1.910	2.200
Height entrance ³	1.285	1.450
Height exit³	1.155	1.320
Pump: length (mm)	216	216
width (mm)	172	172
height (mm)	216	216
Total length (mm)	2.360	2.580
Total width (mm)	2.360	2.580
Total height (mm)	1.900	2.250
Total weight (Kg)	330	370

³ of the system, measured from ground surface





14. Overview of the impact of certain substances and alternative products

Group/subgroup	Detrimental degree		Alternatives	
	*	explanation	Reasonable	Good
LAUNDRY DETERGENTS				
Pre-washing	-		Pre-treat stains	No prewash or e.g. soak in soda
Main detergent	-		Phosphate free products with e.g. zeolite as P-replacement	For handwash: natural soap and soda
Fabric softener	--	Contains compounds that are difficult to degrade	Minimal dosing, skip for hand towels and dish towels	Hang laundry outside
DISH WASHING				
Detergents for dishwash by hand	O		Minimize use	Phosphate and chloride free
Dish washer	--		Minimize use of softener salts	Rince with clean water
Polish	--		Minimize use	
Pre-rinsing (kitchen waste, food remains)	O		in compostable waste container	
CLEANING PRODUCTS AND DESINFECTANTS				
Total cleaner	-		Minimize use	Abrasive spunch or fine sand (not in sink)
Bleach	---		Hydrogen peroxide	
Abrasive soap	-		Without bleach, without chlorides	Mechanical unblocking
Unblocking agent	---		Minimize use	
Bath cleaning agent	--		Minimize use	Diluted vinegar (<5%)
Decalcination agents	-		Minimize use, do not use EDTA based products.	Diluted vinegar (<5%)
Ruitenreinigingsmiddel	--		Minimize use	Water with vinegar, formic acid solutions (Odoured) Natural soap (Odoured) natural soap pads
Toilet cleaner	--		Minimize use	
Toilet cubes, pads	--		Use environmental-friendly products	
Ontsmettingsmiddelen	--		Minimize use. Do not flush remains, and do not throw remains in the sink	Iodine based products instead of synthetic and chloride based products

* Legend :

- O Harmless
- Limited harm
- Moderate Harm
- Very harmful



Group/subgroup	Detrimental degree		Alternatives	
		Explanation	Reasonable	Good
PERSONAL HYGIENE Soap Bath foams Shampoo Toilet papers Other	O - - O ---	Washed-off contaminants can have a negative effect	No disinfecting or aggressive soaps Minimal use No solid substances (e.g. tampons, sanitary towels or napkins,..) They can be disposed of with the household waste	Natural soaps, possibly mixed with sand or chalk (CaCO ₃).
MEDICINE	---	Mainly antibiotics can have a damaging effect	Do not flush or throw remains via the toilet or sink	
PESTICIDES	---		Do not flush or throw remains via the toilet or sink. Do not rinse or clean pesticide bottles or containers in the sink	
DESINFECTANTS	---		No chloride based products	Iodine based products; In case of use of larger volumes to not flush remains or rinse bottles and containers in the sink
PAINTS Wall paints (water-based) Thinners Brush cleaners Paint stripper Carboleum Waterproofing agent Transparent and covering pickles, primers, varnish	-- -- -- --- --- -- --	Mainly organochlorines are damaging Contains terpenes	Do not flush or throw remains via the toilet or sink Do not rinse or clean bottles, containers or brushes in the sink	Use of linseed oil. Burn off paints (if possible)
PHOTOCHEMICALS	--		Do not flush or throw remains via the toilet or sink. Do not rinse or clean bottles or containers in the sink	
MOTOR/ENGINE PRODUCTS Oil Radiator Reinigingsmiddelen	-- -- -	Gives extra loads to the installation	Do not flush or throw remains via the toilet or sink. Do not rinse or clean bottles or containers in the sink Minimize use	

15. Available accessories

1. Pedestrian covers in plastic
2. Extra air hose
3. Sample pit



16. Warranty

We offer a 10-year warranty on all our products for manufacturing defects, except the aeration pumps and other electric or mechanical, ... parts which carry a 2-year warranty. Failure to comply with installation procedures and guidelines will void the warranty.

The terms of Boralit are applicable.

Boralit NV

Nijverheidslaan 12

9880 Aalter (België)

☎ +32 (0) 9 375 11 11

☎ +32 (0) 9 375 22 22

✉ sales@boralit.com

🌐 <http://www.boralit.com>